

TECHNICAL LIST (HS04/HS05)

ROAD BARRIER 100

Technical Product Data:

Our road barriers are a modern and highly efficient way of controlling traffic and preventing vehicles from entering the opposite lanes, or leaving the road. Road barrier systems consist of individual prefabricated components, connected by patented articulated joints into a transversal load-bearing catenary (which also uses friction and shear forces at the base of each component). This reduces the g forces in a vehicle crashing into the barrier. Our barriers may be used as permanent or temporary.

They are designed as flexible barriers and are permanently deformed upon impact. This product line includes single- or double-sided barriers with a height of 1,200 mm. These barriers are a road restraint system as defined in ČSN EN 1317-1 and TKP Chapter 11. 1,200 mm-high concrete barriers are currently the best-quality and most-efficient road restraint system. They are functionally classified as H4, which is the highest restraint level according to ČSN EN 1317-2.

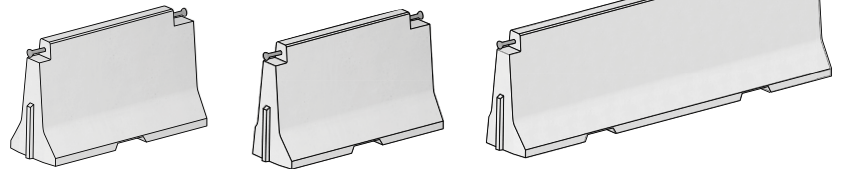
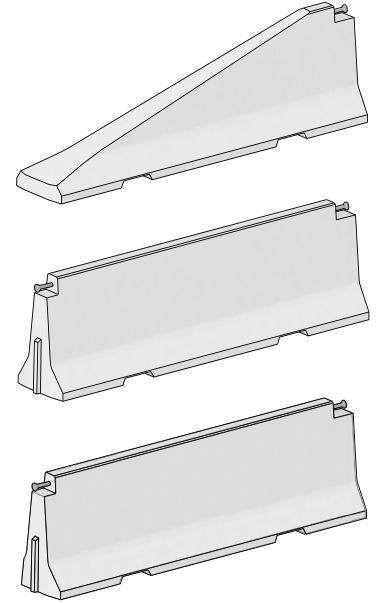

Technical Product Data	Nominal dimensions mm			Weight kg/pcs
	Height	Length	Width	
Double-sided basic unit	1000	4000	695	3158
Double-sided short unit	1000	2000	695	1575
Double-sided end piece - left/right	1000	4000	695	2576
Double-sided transition piece left (concrete/steel)	1000	4000	695	3140
Double-sided transition piece right (concrete/steel)	1000	4000	695	3140
Double-sided transition piece left (high to 1,2 m)	1200 - 1000	4000	695	3380
Double-sided transition piece right (high to 1,2 m)	1000 - 1200	4000	695	3380
Double-sided transition piece left (high to 0,8 m)	800 - 1000	4000	695	2954
Double-sided transition piece right (high to 0,8 m)	1000 - 800	4000	695	2954
Single-sided basic unit	1000	4000	549	2920
Single-sided short unit	1000	2000	549	1457
Single-sided end piece - left/right	1000	4000	549	2343
Single-sided transition piece left (concrete/steel)	1000	4000	549	2885
Single-sided transition piece right (concrete/steel)	1000	4000	549	2885
Single-sided transition piece left (high to 1,2 m)	1200 - 1000	4000	549	3143
Single-sided transition piece right (high to 1,2 m)	1000 - 1200	4000	549	3143
Single-sided transition piece left (high to 0,8 m)	800 - 1000	4000	549	2716
Single-sided transition piece right (high to 0,8 m)	1000 - 800	4000	549	2716
Handrail for Jersey barrier	500	3890	-	17,5

Joint cover:

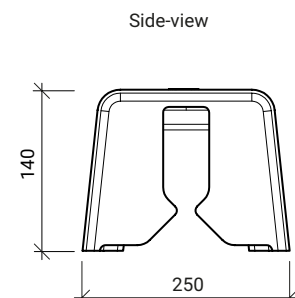
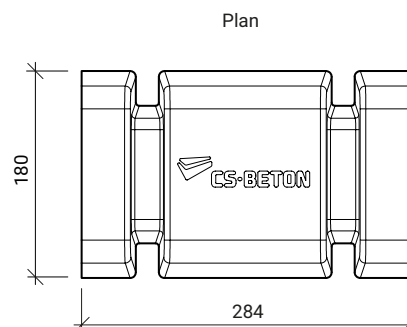
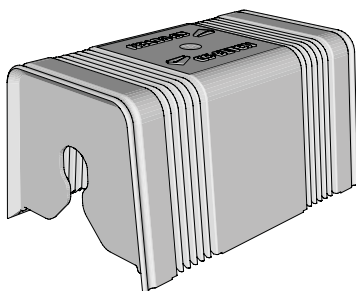

TECHNICAL LIST (HSO4)

ROAD BARRIER 100 DOUBLE - SIDED

Nominal dimensions - basic shapes:

Basic segment

Plan

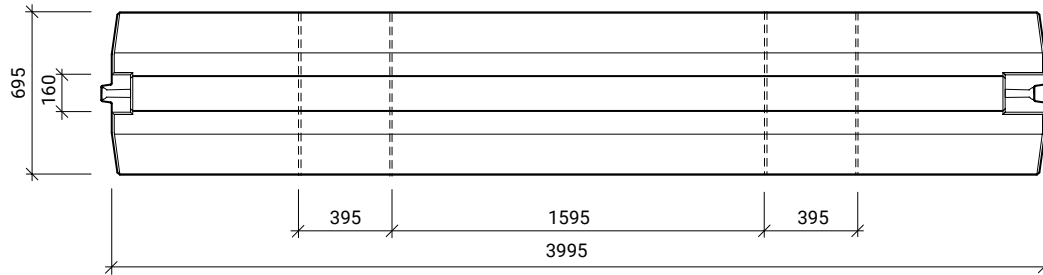

Front-view

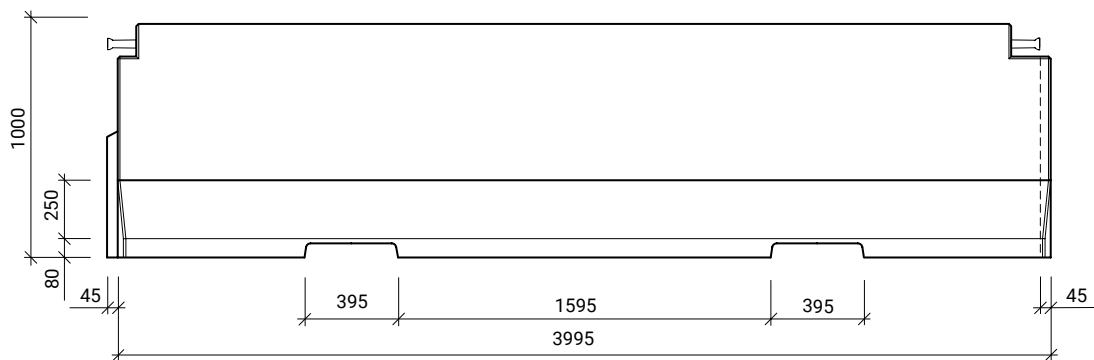

Side-view



TECHNICAL LIST (HSO4)

ROAD BARRIER 100 DOUBLE - SIDED

Nominal dimensions - basic shapes:

End segments - right

Plan

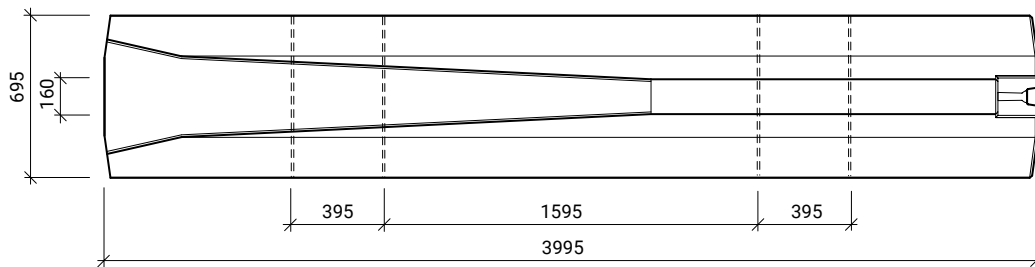

Front-view

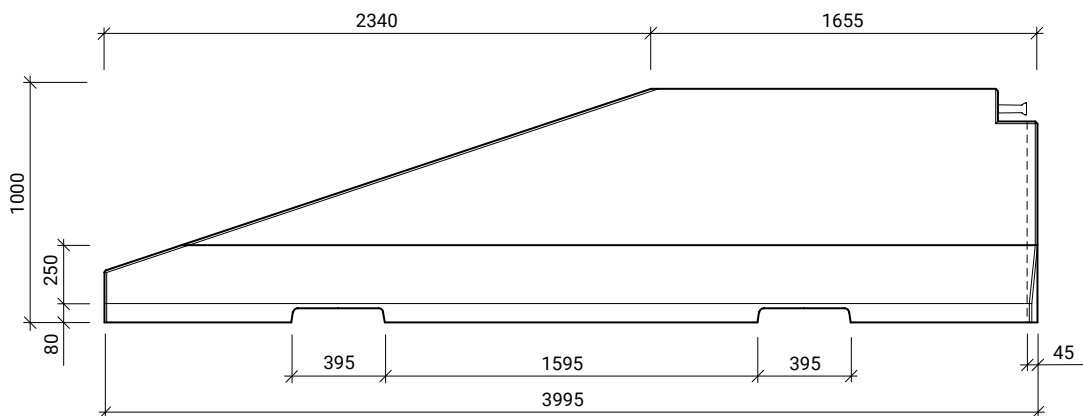

Side-view



TECHNICAL LIST (HSO4)

ROAD BARRIER 100 DOUBLE - SIDED

Nominal dimensions - basic shapes:

Transition piece (concrete/steel - right)

Plan

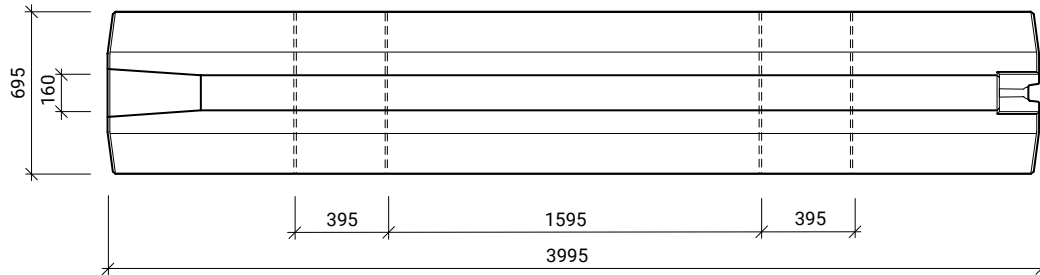

Front-view

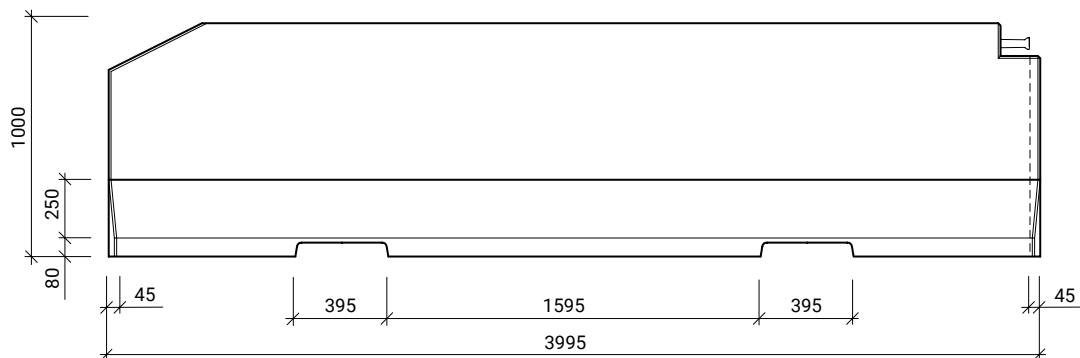

Side-view



TECHNICAL LIST (HSO4)

ROAD BARRIER 100 DOUBLE - SIDED

Nominal dimensions - basic shapes:

Transition piece right (high to 0,8 m)

Plan

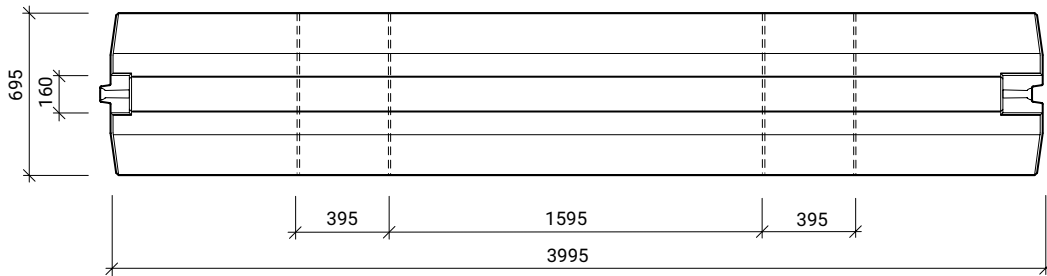

Front-view

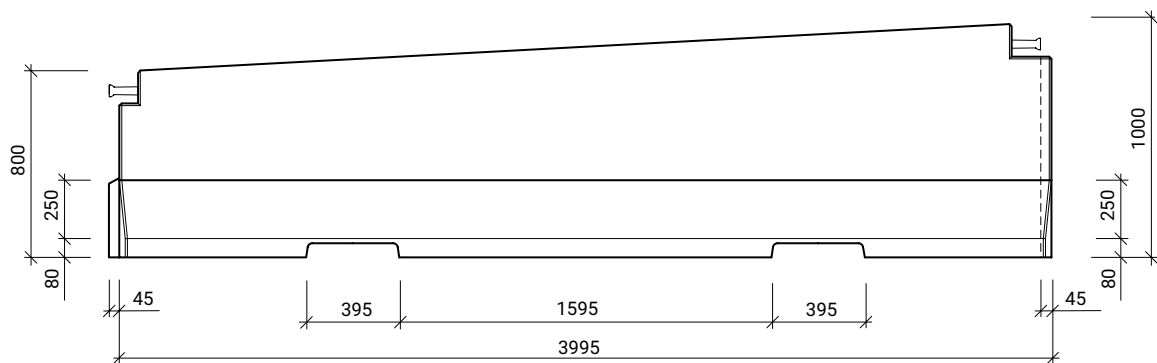

Side-view



TECHNICAL LIST (HSO4)

ROAD BARRIER 100 DOUBLE - SIDED

Nominal dimensions - basic shapes:

Short unit

Plan

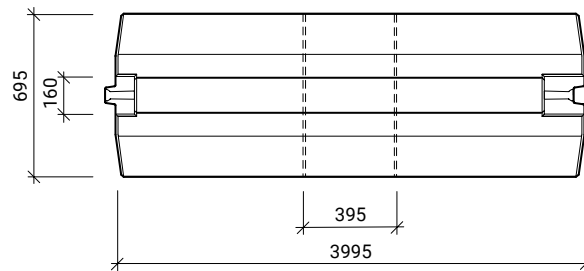

Front-view

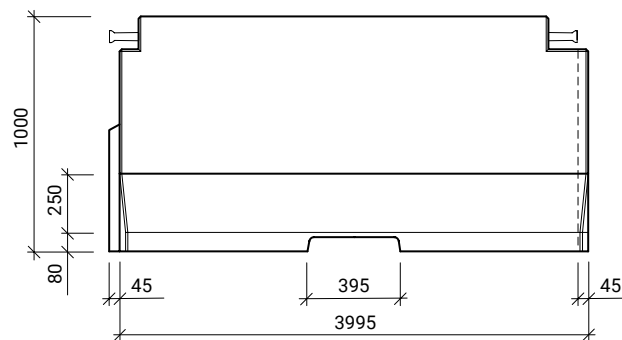

Side-view



TECHNICAL LIST (HS05)

ROAD BARRIER 100 SINGLE - SIDED

Nominal dimensions - basic shapes:

Basic segment

Plan

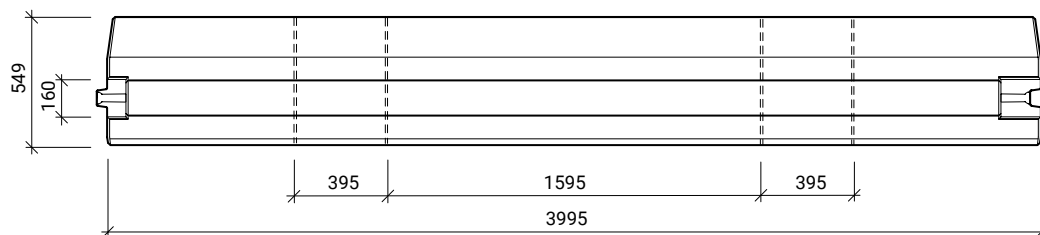

Front-view

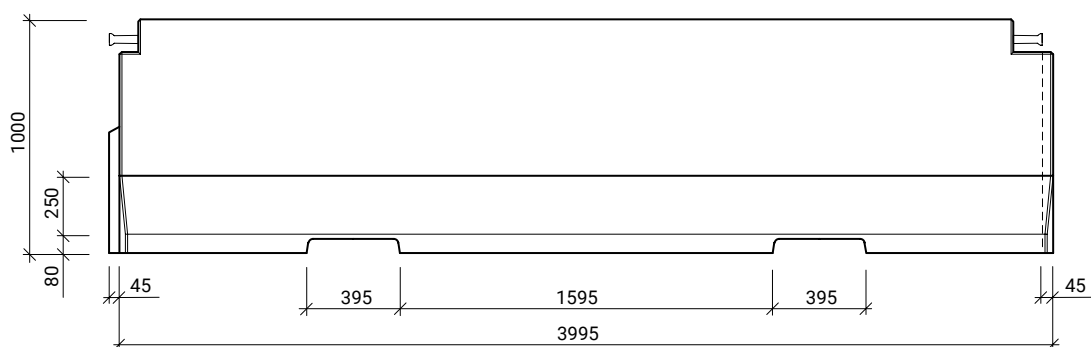

Side-view



TECHNICAL LIST (HS05)

ROAD BARRIER 100 SINGLE - SIDED

Nominal dimensions - basic shapes:

End segments - left

Plan

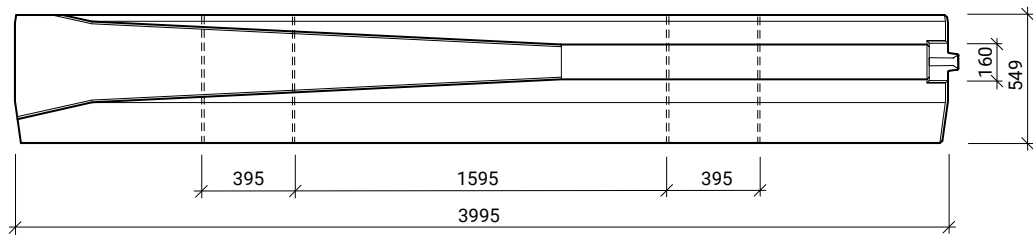

Front-view

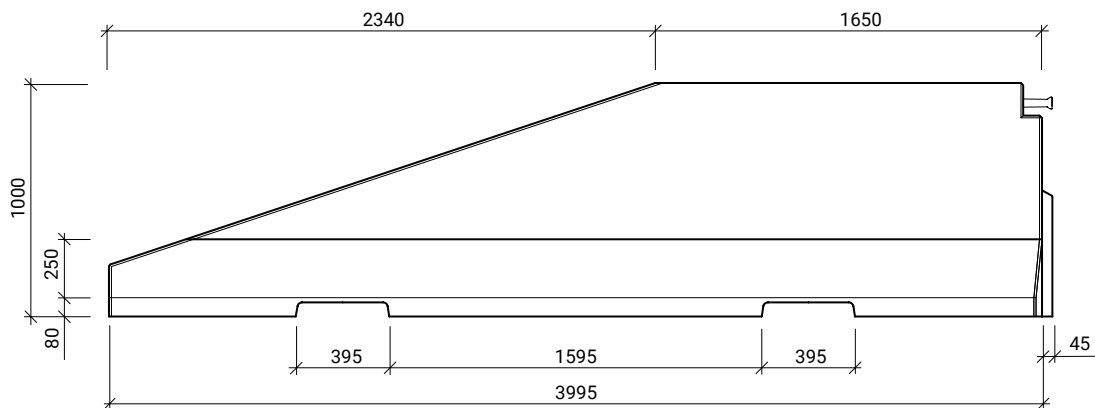

Side-view



TECHNICAL LIST (HS05)

ROAD BARRIER 100 SINGLE - SIDED

Nominal dimensions - basic shapes:

Transition piece (concrete/steel - right)

Plan

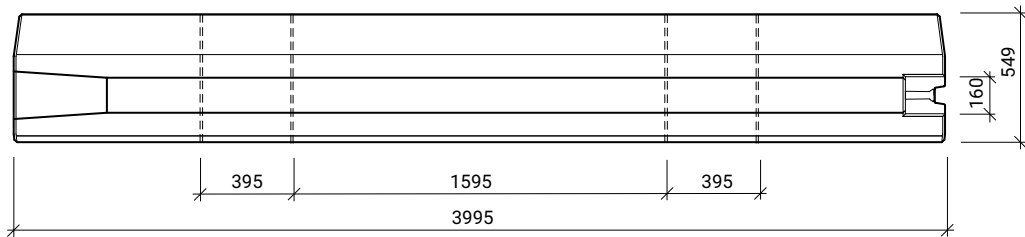

Front-view

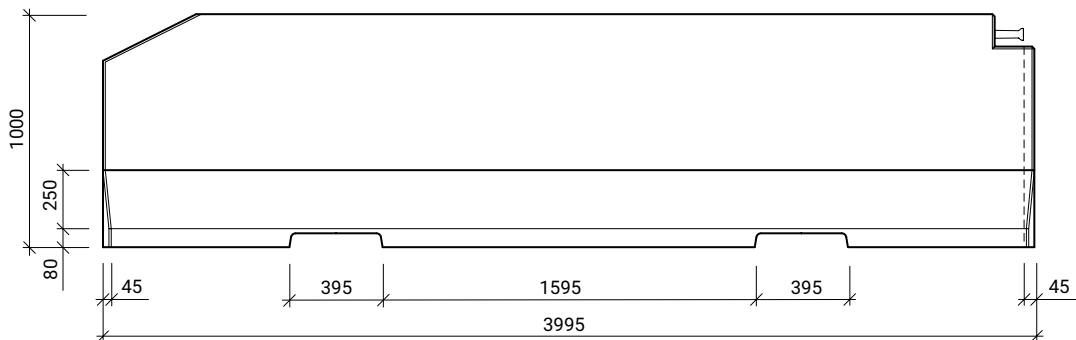

Side-view



TECHNICAL LIST (HS05)

ROAD BARRIER 100 SINGLE - SIDED

Nominal dimensions - basic shapes:

Transition piece left (high to 0,8 m)

Plan

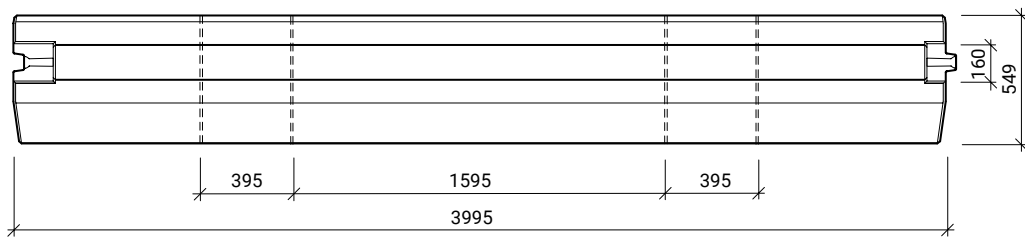

Front-view

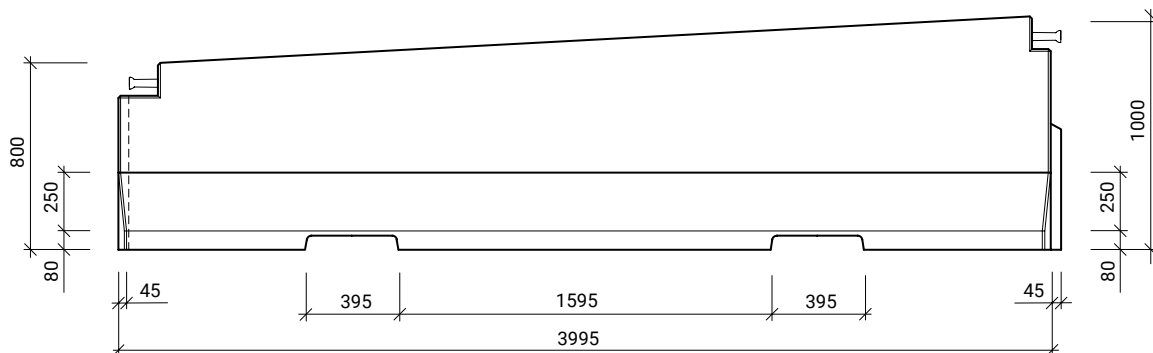

Side-view



TECHNICAL LIST (HS05)

ROAD BARRIER 100 SINGLE - SIDED

Nominal dimensions - basic shapes:

Short unit

Plan

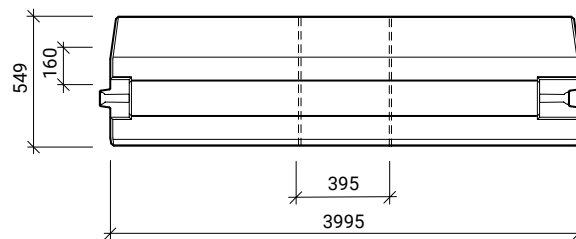

Front-view

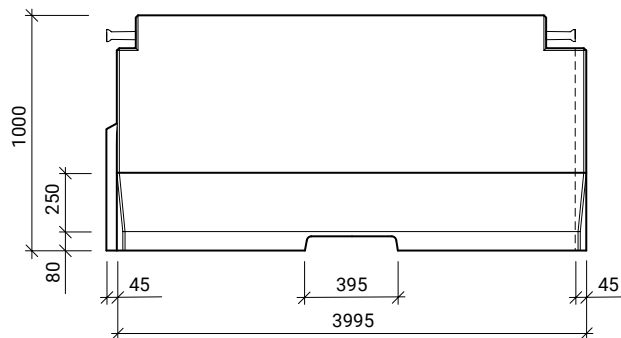

Side-view

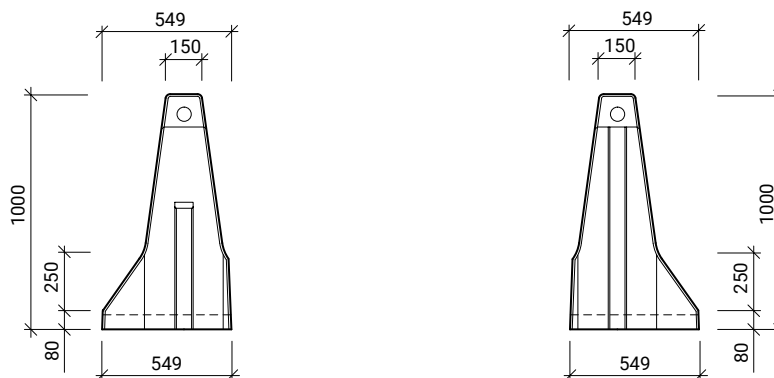

TECHNICAL LIST (HS04/HS05)

ROAD BARRIER 100

PROPERTIES AND CHARACTERISTICS

ROAD BARRIERS 100 are a modern and highly efficient way of controlling traffic and preventing vehicles from entering the opposite lanes, or leaving the road.

CS-BETON produces the following road barriers 100 components:

- Basic road barrier, 4 m long
- Eend piece, 4 m long
- Transition piece (steel/concrete), 4 m long
- Transition piece left (high to 0,8 m), 4 m long
- Additional segments, left or right versions.

Our barriers may be used as permanent or temporary. They are designed as flexible barriers and are permanently deformed upon impact. This product line includes single or double-sided barriers with a height of 1,000 mm. These barriers are a road restraint system as defined in ČSN EN 1317-1 and TKP Chapter 11. 1,000 mm-high concrete barriers are currently the best-quality and most-efficient road restraint system. They are functionally classified as H4, which is the highest restraint level according to ČSN EN 1317-2.

The ROAD BARRIER SYSTEM may be used in applications where both vertical and horizontal angles between individual segments are required (less than 7° and 4° respectively). After initial installation and survey, the segments may be rectified at the joints by tightening or loosening the anchor bolts. The shape is obtained from the angle between individual segments. After completing an entire line, the joints are tightened using an anchoring matrix. Installation requires a truck crane, lifting eyes and self-balancing and rectifiable lifting beams.

The ROAD BARRIER SYSTEM was designed to comply with the following binding technical documents (TKP=Technical Quality Specifications, TP=Technical Specifications):

- ČSN EN 206
- TKP staveb pozemních komunikací/traffic infrastructure structures, Chapter 18 Beton pro konstrukce/Structural concrete (effective from 1/10/2005)
- ČSN EN 1317-1, 2 a 5
- TKP staveb pozemních komunikací /traffic infrastructure structures, Chapter 11 Svodidla, zábradlí a tlumiče nárazů/Barriers, handrails and impact absorbers (effective from 1/ 4/2010)
- TP 114 Svodidla na pozemních komunikacích/Road barriers
- TP 139 Betonové svodidlo/Concrete barriers

The system has been tested as per requirements in the above documents and has fully passed the tests – see certificates and barrier test results. The ROAD BARRIERS are subject to demanding testing performed by independent accredited test labs.

The continuous high quality of our products is ensured by our long experience, top-quality manufacturing equipment, superior source materials, continuous production testing and CS-BETON's ČSN EN ISO 9001 certification, regularly audited by independent quality system auditors.

At bridge expansion joints, the ROAD BARRIER SYSTEMS can be equipped with special expansion joints. These enable movements of ±40 mm while maintaining full static strength. The unique design of these joints does not require the segment faces to be modified in any way and still enables the joint to be easily dismantled when a segment is destroyed. The joint is protected by a special electrical insulation paint, (RILSAN), which prevents stray currents from entering the concrete segments. The RILSAN coating also provides excellent corrosion and mechanical resistance.

Since 2008, CS-BETON is also certified under the ČSN EN ISO 14001 environmental management system.

In 2010, we included health and safety into our certified management systems and currently hold certificates for the following.

TECHNICAL LIST (HS04/HS05)

ROAD BARRIER 100

Expansion joint 0 mm

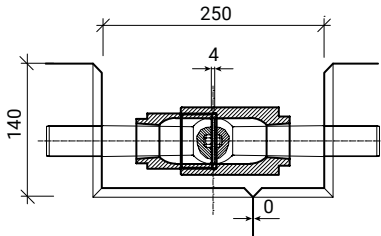

Expansion joint 80 mm

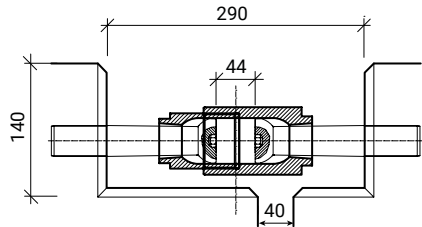

Expansion joint 40 mm

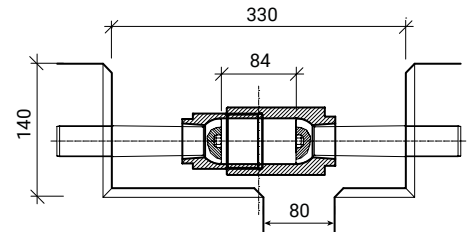

Joint - shop drawing:

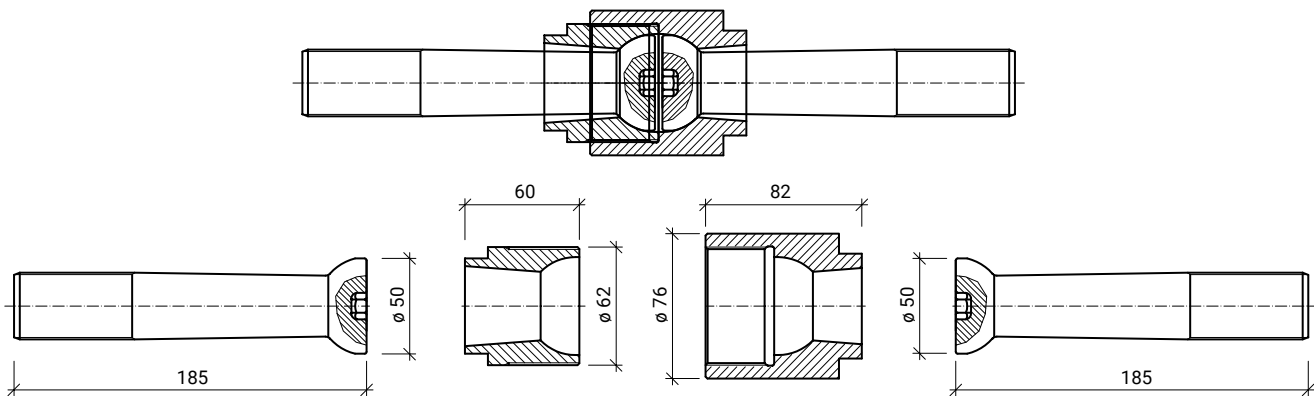

Nominal dimensions - basic shapes:

